

General Description of the Company

Anhui Forklift Group Corporation Ltd. (hereinafter referred as Heli) is a leading enterprise of industrial trucks in China.

Since 2016, Heli has been ranked among the top seven in the world, representing Chinese brands to forge ahead towards higher stage. (According to the "Top 20 Industrial lift truck suppliers" released by MMH.)

As the leading enterprise in China industrial truck industry, Heli has the ability and strength to participate in the global competition in a higher level, larger scale and wider field. Heli has established overseas centers in France, Thailand and the United States, which enhance the service ability in overseas market. Besides, relying on our global partners, we have established an overseas marketing and service network in more than 80 countries and regions, and Heli products are sold to more than 150 countries and regions in the world. In the next five years, Heli will vigorously promote the international operation and create a global famous brand.



CPD 15/16 /18/20 GE2DLI





SMALL BODY,
GREAT ENERGY



GREAT ENERGY

High performance ensures high efficiency



Front wheel with dual drive motor provides more power



17-18km/h
Driving speed



20%
Maximum climbable gradient at full load



0.46m/s
Maximum lifting speed with load



0.65m/s
Maximum lifting speed at full load



Strong carrying capacity on high

Multiple configuration, Low energy consumption



Steering according to the demand of oil, reduce the energy consumption of the vehicle



High precision angle potentiometer makes steering more sensitive and accurate.



The forklift truck is equipped with high brightness, long life, more energy saving LED lights.



Low rolling resistance electric truck special solid tire reduces driving resistance consumption.

Small dimension, More flexible

European small vehicle width is suitable for narrow aisle passage. Large angle steering axle makes the turning radius smaller satisfying the loading and unloading operation in narrow aisle.



The minimum turning radius is as low as **1.74m**

Quick charge, long battery life

- Realizes faster charging; standard 202ah lithium battery has ultra long endurance;
- The characteristics of high-density energy and quick charging of lithium battery make all day uninterrupted operation of a forklift truck.

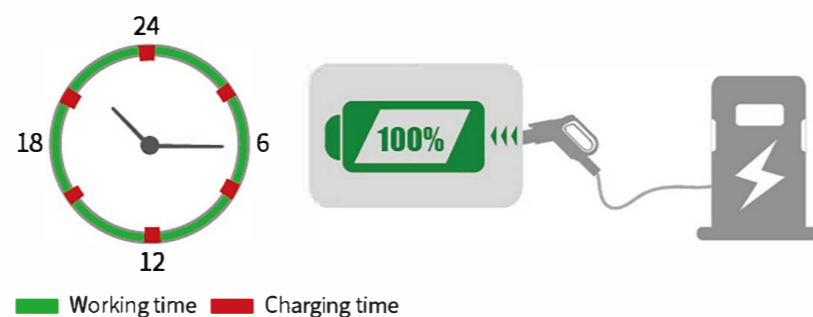

Enjoy driving experience



Alphanumeric display Battery discharge indicator

Keyboard button: Enter Exit button

Hour meter Seat switch LED

Keyboard button: Roll up Handbrake status

Failure alarm LED Keyboard button: Set down

Low battery LED Oil temperature alarm (no use)

Keyboard button: Roll down Keyboard button: Set up

ZAPI Display

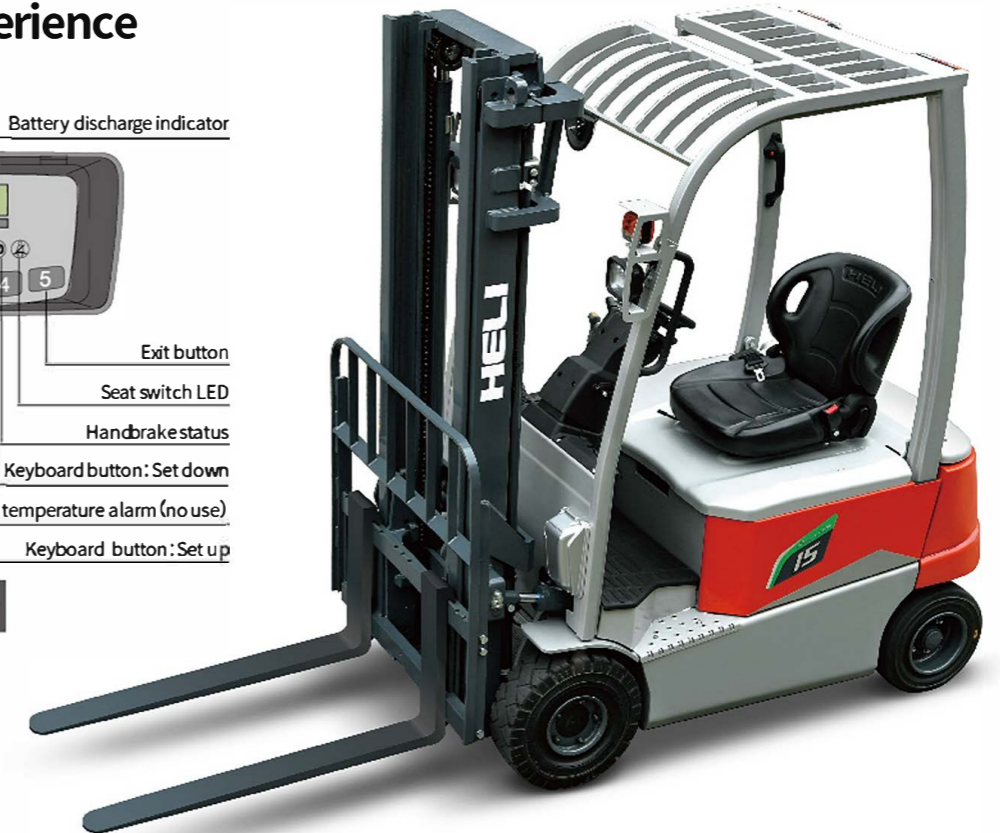

P — Powerful
E — Economical
S — Energy Saving

Multiple performance modes could meet the needs of various working conditions.



Center rearview mirror



New pedal parking system, ergonomic design, very convenient



USB power supply



Storage box



The mast with large opening offers good driving vision ensuring operation comfort and safety.



Large space to get on, and large leg space, more comfortable operation

Intelligent security protection

Intelligent induction of mast taking off and landing can avoid limit impact, and it is safe and comfortable;
Intelligent speed limit in different application: multi application recognition and intelligent speed limit balance efficiency and safety;
Intelligent limit buffer: intelligent induction of mast lifting and lowering avoids limit impact and is safe and comfortable;
Intelligent operation protection: a full set of OPS system can avoid misoperation and ensure safety;
Intelligent control strategy: dual core controller is in line with the latest EU safety requirements.
Intelligent steering deceleration: the automatic deceleration function of the turning can reduce the risk of turning over;
Lithium batteries heat themselves automatically at low temperatures, and their adaptation performances are superior.

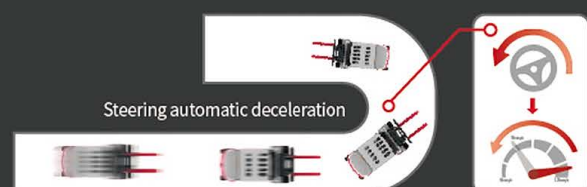
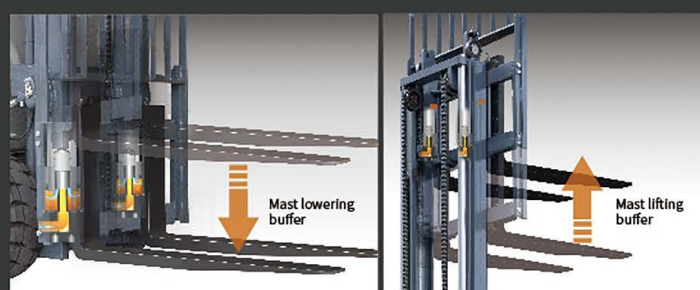
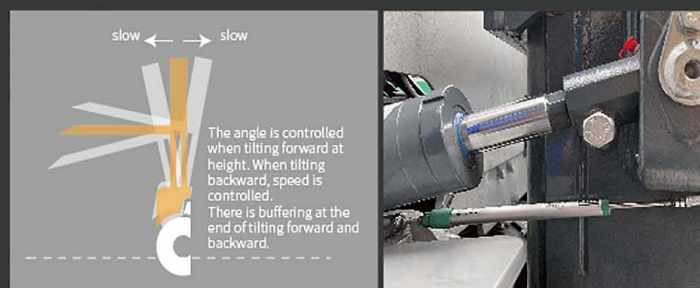

Reliable Quality, Easy Maintenance

The whole vehicle works alternately in the -20°C cold storage and is parked in the cold storage for 12 hours.
 The whole vehicle is trouble-free and can run sustainably.
 The reinforced casting steering axle is mature and reliable. The force optimization design of mast improves the overall performance and ensure the safety of operation effectively.

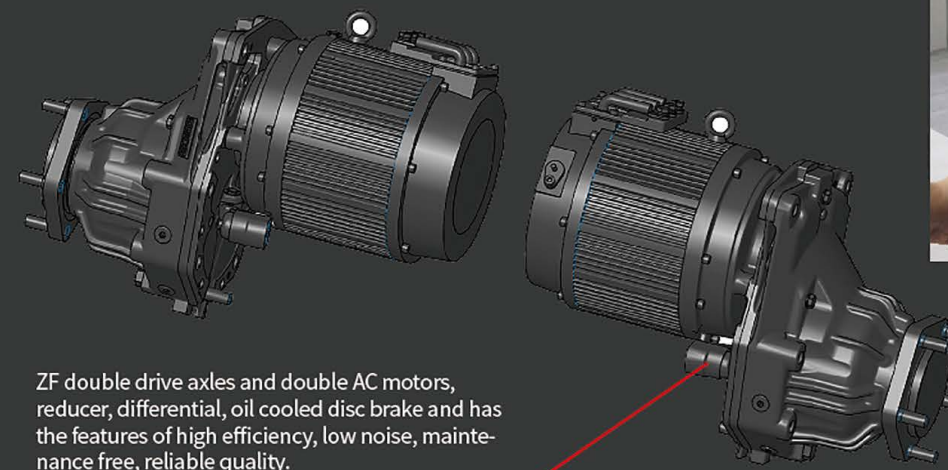

ZF double drive axles and double AC motors, reducer, differential, oil cooled disc brake and has the features of high efficiency, low noise, maintenance free, reliable quality.



Operating Cost Comparison:

Lithium battery forklift **vs.** Lead-acid battery forklift **vs.** IC forklift

The advantages of HELI lithium battery forklift trucks are more prominent in the life cycle cost. Compared with internal combustion forklift truck, lithium battery forklift truck has the advantages of no noise, no pollution, small vibration and simple operation.
 Compared with the lead-acid battery forklift truck, lithium battery forklift has the characteristics of fast charging and charging at any time, which is more suitable for multi shift operation.
 Besides, HELI Lithium-ion Battery Forklift is maintenance-free, with high energy conversion, saving a lot of operating costs.

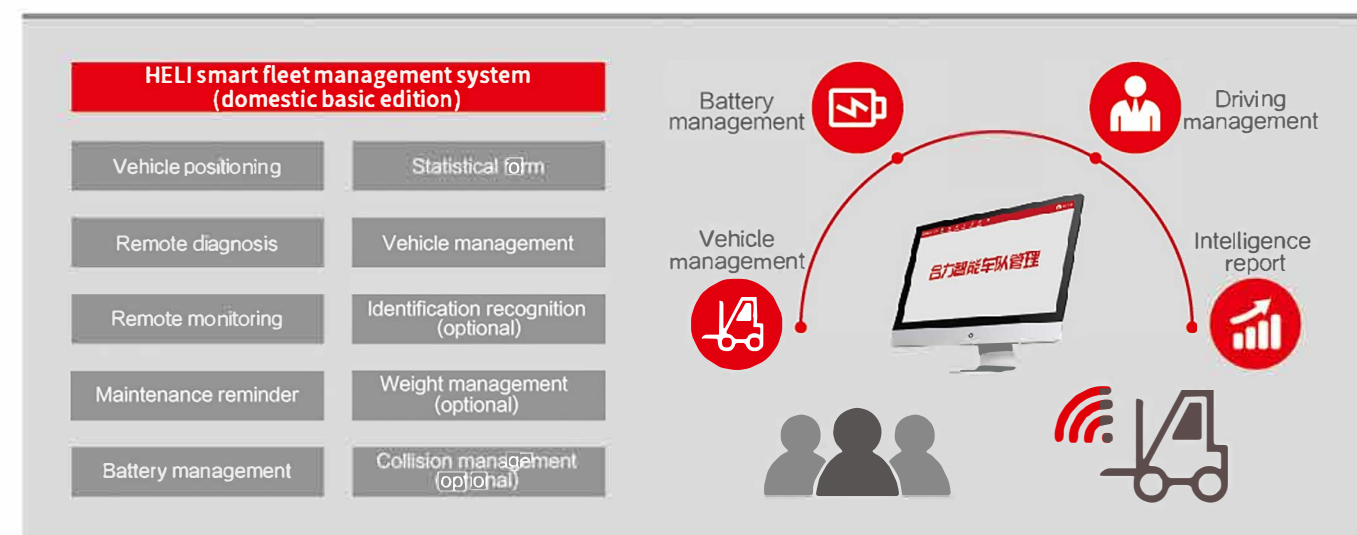
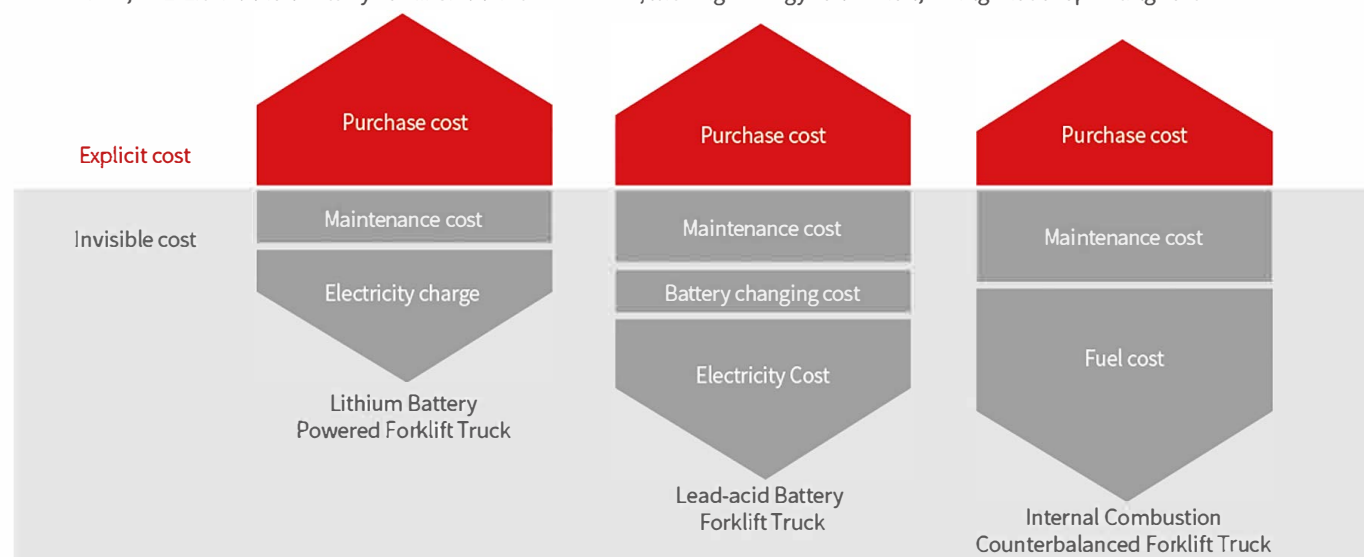

Manufacturer and Technical Data							
Characteristics							
1.01	Manufacturer			HELI			
1.02	Model		CPD15	CPD16	CPD18	CPD20	
1.03	Configuration number		GE2DLI	GE2DLI	GE2DLI	GE2DLI	
1.04	Rated capacity	Q	kg	1500	1600	1800	2000
1.05	Load center distance	c	mm		500		
1.06	Power mode			Battery			
1.07	Driving mode			Seated			
1.08	Load distance, center of drive axle to fork	x	mm	367	367	367	372
1.09	Wheelbase	y	mm	1292	1292	1400	1400
Weight							
2.01	Total weight (with/without battery)		kg	2915/2635	3015/2735	3180/2900	3380/3100
2.02	Axle load (laden, front/rear)		kg	3895/520	4045/570	4390/590	4700/680
2.03	Axle load (unladen, front/rear)		kg	1365/1550	1385/1630	1430/1750	1450/1930
Tyres							
3.01	Tyre type			SE			
3.02	Tyre size, front			18X7-8	18X7-8	200/50-10	200/50-10
3.03	Tyre size, rear			140/55-9	140/55-9	16X6-8	16X6-8
3.04	Wheels, number front/rear (x=driven wheels)			2x/2	2x/2	2x/2	2x/2
3.05	Tread, front	b ₁₀	mm	910	910	920	920
3.06	Tread, rear	b ₁₁	mm	890	890	910	910
Dimensions							
4.01	Mast tilt angle (forward/backward)	α/β	°	5/7	5/7	5/7	5/7
4.02	Height (mast lowered)	h ₁	mm	2175	2175	2175	2175
4.03	Free lifting height	h ₂	mm	90	90	90	90
4.04	Lifting height (standard)	h ₃	mm	3300	3300	3300	3300
4.05	Max. height, extended	h ₄	mm	4039	4039	4039	4039
4.06	Height of overhead guard	h ₆	mm	2040	2040	2040	2040
4.07	Height of seat	h ₇	mm	1047	1047	1064	1064
4.08	Towing coupling height	h ₁₀	mm	375	375	375	375
4.09	Overall length (with fork)	l ₁	mm	2925	2925	3000	3000
4.10	Overall length (without fork)	l ₂	mm	2005	2005	2085	2085
4.11	Overall width	b ₁	mm	1060/1076	1060/1076	1060/1120	1060/1120
4.12	Fork carriage, DIN standard			2A	2A	2A	2A
4.13	Fork size: thickness x width x length	s/e/l	mm	35/100/920	35/100/920	35/100/920	40/122/920
4.14	Distance between fork-arms, Max./Min.	b ₅	mm	960/200	960/200	960/200	960/200
4.15	Ground clearance (laden, between mast)	m ₁	mm	90	90	90	90
4.16	Ground clearance (laden, center of wheelbase)	m ₂	mm	100	100	100	100
4.17	Right angle stacker aisle width for pallet 1000x1200mm crossways	A _{st}	mm	3315	3315	3420	3420
4.18	Right angle stacker aisle width for pallet 800x1200mm lengthways	A _{st}	mm	3515	3515	3620	3620
4.19	Min. outside turning radius	W _a	mm	1745	1745	1845	1845
Performance Data							
5.01	Running speed		km/h	17/18	17/18	17/18	17/18
5.02	Lifting speed		m/s	0.46/0.65	0.46/0.65	0.42/0.6	0.42/0.6
5.03	Lowering speed (laden/unladen)		m/s	0.55/0.5	0.55/0.5	0.55/0.5	0.55/0.5
5.04	Max. drawbar pull (laden/unladen)		N	17500/11200	17500/11200	18500/11500	18500/11500
5.05	Max. gradeability (laden/unladen)		%	22/30	22/30	22/30	22/30
5.06	Acceleration time(10 m)(laden/unladen)		s	5.4/5	5.4/5	5.4/5	5.4/5
Battery							
6.01	Battery voltage/Capacity		V/Ah	80/202	80/202	80/202	80/202
6.02	Battery weight (Min./Max.)		kg	260/320	260/320	260/320	260/320
Motor and controller							
7.01	Driving motor powering (S2-60min)		kW	6X2	6X2	6X2	6X2
7.02	Lifting motor powering (S3-15%)		kW	17.6	17.6	17.6	17.6
7.03	Driving motor controlling mode			MOSFET/AC			
7.04	Lifting motor controlling mode			MOSFET/AC			
Addition data							
8.01	Service brake/Parking brake			Hydraulic/Hydraulic(automatic parking)			
8.02	Operating pressure for attachments		Mpa	17.5	17.5	17.5	17.5

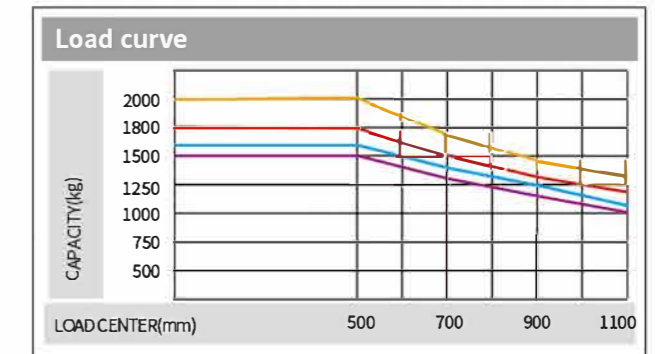
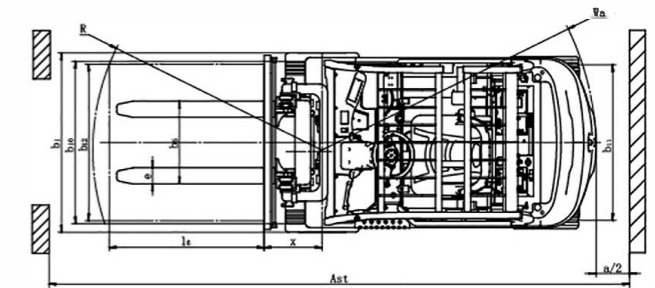
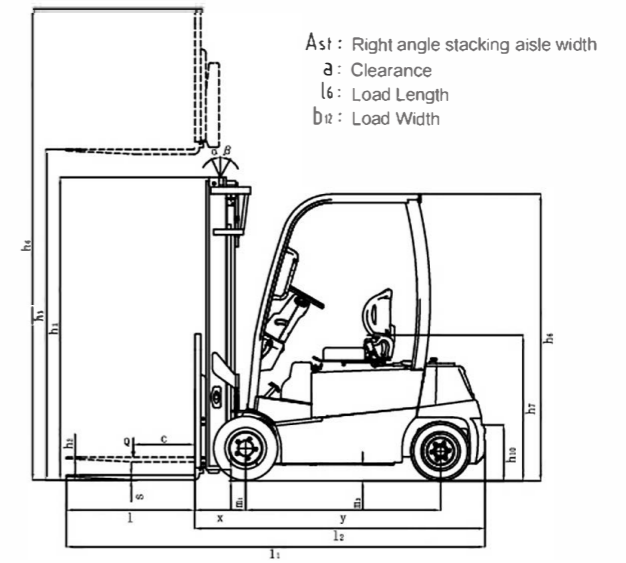

CPD15 CPD16 CPD18 CPD20

Note:The vertical axis stands for load capacity while the horizontal axis stands for load center which is calculated from the front surface of the forks to the gravity of the standard load. the standard load means a cubic with 1000mm edge length. When the mast is tilted forward, the worker using nonstandard forks for loading large goods, the load capacity will be reduced. The load capacity of standard mast at different load center can be known from this load chart.

Note: Configuration 2: ZAPI; 3:INMOTION; 6: HELI Technology

WIDE VIEW MAST											
mast model	Max lifting height mm	load capacity (load center 500mm)				mast overall height (fork to the ground)	service weight				mast tilting angle (°) α/β
		1.5t	1.6t	1.8t	2.0t		1.5-2t	1.5t	1.6t	1.8t	
M200	2000	1500	1600	1800	2000	1525	2843	2943	3099	3299	5-7
M250	2500	1500	1600	1800	2000	1775	2870	2970	3136	3336	5-7
M300	3000	1500	1600	1800	2000	2025	2899	2999	3164	3364	5-7
M330	3300	1500	1600	1800	2000	2175	2915	3015	3180	3380	5-7
M350	3500	1500	1600	1800	2000	2275	2926	3026	3191	3391	5-7
M370	3700	1500	1600	1800	2000	2375	2937	3037	3202	3402	5-7
M400	4000	1500	1600	1800	2000	2575	2980	3080	3245	3445	3-5
M425	4250	1500	1600	1800	2000	2700	3023	3123	3288	3488	3-5
M450	4500	1500	1600	1800	2000	2825	3038	3138	3303	3503	3-5
M500	5000	1250	1350	1600	1750	3075	3069	3169	3334	3534	3-5
M550	5500	1100	1250	1350	1500	3375	3127	3227	3392	3592	3-3
M600	6000	900	1000	1100	1300	3625	3158	3258	3423	3623	3-3

WIDE VIEW FULL FREE 2-STAGE MAST												
mast model	Max lifting height mm	load capacity (load center 500mm)				mast overall height (fork to the ground)	free lifting height (with backrest)	service weight				mast tilting angle (°) α/β
		1.5t	1.6t	1.8t	2.0t			1.5-2t	1.5t	1.6t	1.8t	
ZM200	2000	1500	1600	1800	2000	1525	510	2870	2970	3135	3335	5-7
ZM250	2500	1500	1600	1800	2000	1775	760	2899	2999	3164	3364	5-7
ZM300	3000	1500	1600	1800	2000	2025	1010	2927	3027	3192	3392	5-7
ZM330	3300	1500	1600	1800	2000	2175	1160	2945	3045	3210	3410	5-7
ZM350	3500	1500	1600	1800	2000	2275	1260	2956	3056	3221	3421	5-7
ZM370	3700	1500	1600	1800	2000	2375	1360	2970	3070	3235	3435	5-7
ZM400	4000	1500	1600	1800	2000	2575	1560	3015	3115	3280	3480	3-5

WIDE VIEW FULL FREE 3-STAGE MAST												
mast model	Max lifting height mm	load capacity (load center 500mm)				mast overall height (fork to the ground)	free lifting height (with backrest)	service weight				mast tilting angle (°) α/β
		1.5t	1.6t	1.8t	2.0t			1.5-2t	1.5-2t	1.5t	1.6t	
ZSM360	3600	1500	1600	1800	2000	1790	781	3059	3159	3324	3524	3-5
ZSM400	4000	1500	1600	1800	2000	1925	916	3084	3184	3349	3549	3-5
ZSM435	4350	1500	1600	1800	2000	2040	1031	3112	3212	3377	3577	3-5
ZSM450	4500	1500	1600	1800	2000	2090	1081	3123	3223	3388	3588	3-5
ZSM470	4700	1400	1500	1700	1900	2160	1151	3139	3239	3401	3601	3-5
ZSM480	4800	1350	1450	1650	1850	2190	1181	3144	3244	3406	3606	3-5
ZSM500	5000	1250	1350	1600	1750	2290	1281	3166	3266	3428	3628	3-5
ZSM540	5400	1100	1250	1350	1500	2425	1416	3222	3322	3484	3684	3-3
ZSM600	6000	900	1000	1100	1300	2640	1631	3262	3362	3524	3724	3-3
ZSM650	6500	800	900	1000	1200	2830	1821	3304	3404	3566	3766	3-3

LITHIUM BATTERY CHARGER					
Lithium battery brand	HELI		CATL		EIKTO
Voltage/Capacity	80V/202	80V/271	80V/202	80V/271	80V/271
CPD15/16/18/20SQ	●	○	○	○	○
Low temperature heating of lithium battery			●		
Charger	D80V200ALi-123 D80V200ALi-423				
Note: ● standard ○ optional — non-configurable					

Optional			
Security class	Steering automatic deceleration	●	
	Reversing handle with horn button	●	
	OPS system(Excluding descent)	●	
	Complete OPS system	○	
	Seat belt switch	●	
	Multi way valve overload	●	
	Fire extinguisher	○	
	Backward buzzer	●	
	Reversing Chinese language horn	○	
	Electronic upper buffer	●	
	Rearview mirror with angle in the middle	●	
	Left and right rear mirror	○	
	Tilt speed limit	●	
	Active stabilization(Lifting height 4m and above)	●	
Comfort class	Standard seat	●	
	Fully suspended seat	○	
	USB power	●	
	Mechanical valve	●	
	Solenoid valve (proportional valve + thumb switch)	-	
	Fan	○	
	Color screen instrument	●	
	Heater		
	Performance mode control	●	
	Steering wheel with operation ball	●	
	Steering wheel without operation ball	○	
	The height of overhead guard is increased by 50mm	○	
	Overhead guard with protective net	○	
	Cab/windshield glass	Cab	○
Fit the front windshield		○	
Equipped with rear windshield		○	
Light class	Equipped with top rain glass	○	
	No rear work lights or rear blue lights	●	
	LED rear work light	○	
	LED rear blue light (without switch control)	○	
	led rear work light and led rear blue light (without switch control)	○	
	LED flickering warning light	●	
	LED rotary warning light	○	
	Led rotary buzzer warning light	○	
	Other	HEDING lithium battery	●
		ENEROC lithium battery	○
		EIKTO lithium battery	○
		Solid tire	●
		Traceless tyre	○
		Single tire (front wheel)	●
Double tire (front wheel)		-	
Metric thread		●	
American thread		○	
Sleeve for Tilting cylinder		○	
Tilting cylinder,sleeve for steering cylinder		○	
HELI package		●	
Neutral package		○	
Chinese sticker		●	
English sticker	○		
Custom-made sticker	○		
HELI smart fleet management system(standard version)	○		

Note: ● standard ○ optional — non-configurable