

Reliable special designed instrument

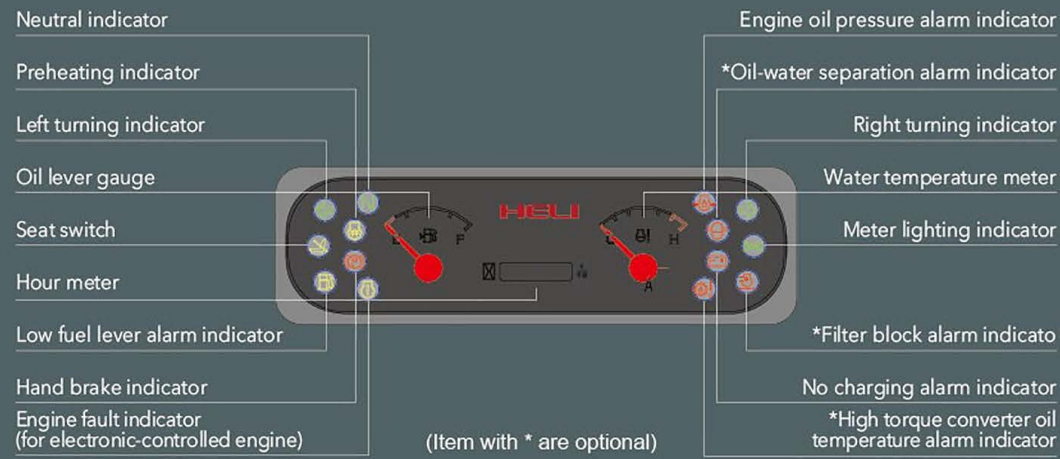

Reliable special meter display the whole truck's working condition, fault detect and other important information completely which make the operator master the whole truck condition directly and conveniently.

Standard configuration

- Horn
- Control valve
- Wholly hydraulic-powered steering
- Half enclosed seat
- Backrest
- Back view mirror
- Front combined lamp
- Transmission oil filter
- Engine flame out device
- Cable type parking brake
- Driver's tool
- Rear combined lamp
- Backward buzzer
- Tilt oil circuit self lock valve
- Tilt adjustable steering column
- Overhead guard rain cover
- Standard fork
- Integrated electric box
- Hydraulic oil circuit filter
- Flow regulator
- Wide view mast
- Air intaking device
- Durable tread tyre
- Lifting and tilting operation lever
- Traction pin
- Headlamp
- Hydraulic oil dipstick
- Overhead guard
- Torque converter oil dipstick
- Combined instrument
- Electro-hydraulic direction changing

Optional

- Driver's cab
- Warning light
- High air exhausting device
- Double air cleaner
- Suspension seat
- Lengthening fork extension
- Warm air blower
- Solid tyre
- Widen fork arm carrier
- Wind shield
- Cleansing muffler
- Fire extinguisher muffler
- Fire extinguisher
- Rear working light
- Air conditioner (certain type)
- Travelling control system
- Torque converter oil temperature meter
- Tilting cylinder bush
- Customermade color
- Optional attachments
- Steel protection net
- Double-tyre and protection device
- Rotating seat for lpg
- Single/dual fuel system
- Low speed alarm

2-3.5 t H3 series
Internal Combustion
Counterbalanced Forklift Truck



Improved performance, *superior quality*



↓ *Vibration 20% reduced*

↓ *Noise 3dB reduced*

- > Cushion connection and wholly suspension driver's cab absorb whole truck's vibration effectively.
- > Noise around ear is reduced through down the tilting cylinder under the floor board and using fully closed patch type driver's cab.
- > Lower damping device inside the lifting system reduces mast shock and vibration, avoiding crash noise caused by goods falling to the ground.

↑ *Workspace 45% increased*

- > Space around foot is effectively increased through up steering unit and using suspension type inching.
- > The operation space is enlarged by heightened overhead guard and using large arc shape of the overhead guard's front leg
- > Semi-suspension seat, steering wheel with small diameter, electro-hydraulic direction changing and automobile type double joystick combined switch effectively improve driving comfort.

↑ *Operator's view 20% improved*

- > Operator's front view is improved through the assembling of stand wide view mast and lowering the dashboard.
- > Operator's rear view improved through the CAE optimal designed counterweight.



↑ *Working efficiency 20% improved*

- > Small turning radius makes steering flexible and easy.
- > The truck has fast lifting speed, good gradeability and high efficiency.
- > High working efficiency guarantees the truck could meet the requirements for various kinds of complicated work condition perfectly wherever at port, dock and railway station.

↑ *Loading capacity increased over 5%*

↑ *Stability 5% improved*

↑ *Reliability 40% improved*

- > The hot air reflow isolating device, optimal thermal dissipation duct and aluminum plate-fin type radiator improve cooling ability and ensure engine work reliability.
- > Automobile type oil filling cap and optimal oil filling channel structure and process ensure whole truck's safety.
- > The constant displacement pump load sensing steering system increases the lifting speed and reduces the hydraulic oil temperature.
- > The optimal design of key parts like frame, mast, overhead guard and steering axle improve the whole truck's safety and reliability.
- > The retroposition of whole truck's gravity center improve loading capacity, stability and safety.

↑ *Engine hood open angle increased to 80°*

- > Enlarged internal space is convenient for engine and transmission box maintenance.
- > Increased hood open angle contributes to quick and convenient maintenance.



2-3.5t H3 series Internal Combustion Counterbalanced Forklift Truck



Manufacturer and technical parameters

Character		HELI					
1.01	Manufacturer	HELI					
1.02	Model	CPC20 / CPCD20 / CP(Q)(Y)D20	CPC25 / CPCD25 / CP(Q)(Y)D25	CPC30 / CPCD30 / CP(Q)(Y)D30	CPC35 / CPCD35 / CP(Q)(Y)D35		
1.03	Rated capacity	kg	2000	2500	3000	3500	
1.04	Load center	mm	500				
1.05	Operation mode	Seat-type					
Size							
2.01	Max.lifting height	H	mm	3000	3000	3000	3000
2.02	Mast overall height(Fork to the ground and mast be vertical)	H1	mm	2000	2000	2065	2180
2.03	Max.fork lifting height(With backrest)	H2	mm	4030	4030	4245	4235
2.04	Free lift height	H3	mm	165	165	160	170
2.05	Overall height(Overhead guard)	H4	mm	2150	2150	2170	2170
2.06	Min.ground clearance(At the mast)	H5	mm	115	115	135	135
2.07	Distance from the surface of the seat to the overhead guard	H6	mm	1030	1030	1030	1030
2.08	Traction pin height	H9	mm	275	275	280	280
2.09	Backrest height(Calculated from the surface of the fork)	H13	mm	1000	1000	1227	1222
2.10	Overall length(With fork/Without fork)	(L/L')	mm	3500/2580	3708/2638	3818/2748	3836/2766
2.11	Wheel base	L1	mm	1650	1650	1700	1700
2.12	Front overhang	L2	mm	473	473	478	496
2.13	Rear overhang	L3	mm	457	515	570	570
2.14	Overall width	W1	mm	1150	1150	1225	1225
2.15	Tread (Front tread/Rear tread)	(W3/W2)	mm	970/970	970/970	1000/970	1000/970
2.16	Fork adjustable range(the external of the fork)(Max./Min.)	W5	mm	1030/244	1030/244	1060/250	1060/250
2.17	Min.turning radius(Exterior)	r	mm	2170	2240	2400	2420
2.18	Min.turning radius(Interior)	r'	mm	180	180	200	200
2.19	Min.right angle stacking aisle width	Ra	mm	2200	2280	2380	2400
2.20	Mast tilting angle	α / β	%	6°/12°	6°/12°	6°/12°	6°/12°
2.21	Fork size	L4×W×T	mm	920×122×40	1070×122×40	1070×125×45	1070×125×50
Weight							
3.01	Total weight	kg	3420	3800	4370	4800	
3.02	Weight distribution loaded (Front/Rear)	kg	4770/650	5480/820	6460/910	7470/830	
3.03	Weight distribution unloaded (Front/Rear)	kg	1600/1820	1560/2240	1710/2660	1880/2920	
Wheel and tyre							
4.01	Wheel number x = drive wheel (Front/Rear)	2X/2					
4.02	Tyre type(Front/Rear)	Pneumatic tyre					
4.03	Tyre size(Front/Rear)	7.00-12-12PR/ 6.00-9-10PR	7.00-12-12PR/ 6.00-9-10PR	28×9-15-12PR/ 6.50-10-10PR	28×9-15-14PR/ 6.50-10-10PR		
4.04	Service brake	Hydraulic-Foot Pedal					
4.05	Parking brake	Mechanical-Hand Lever					

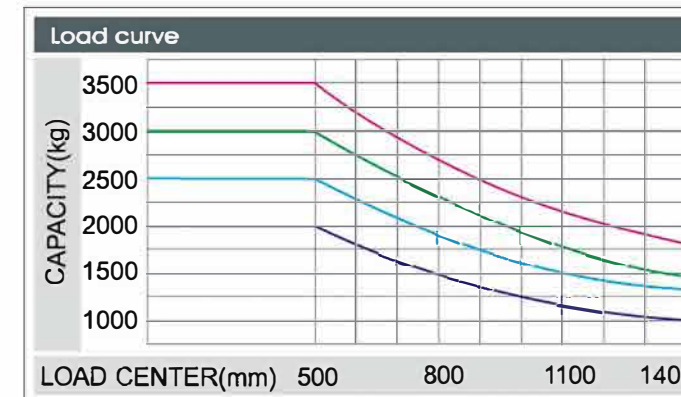
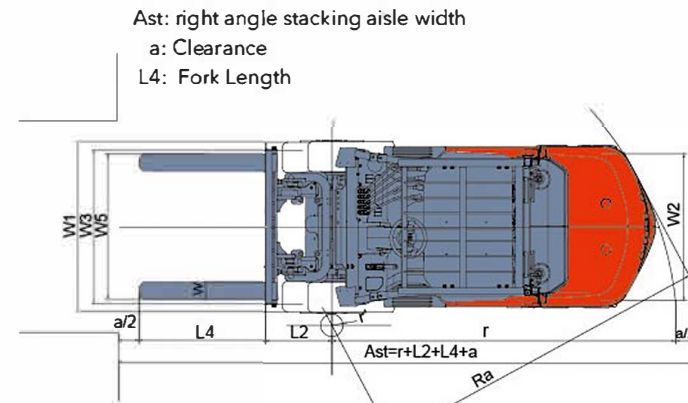
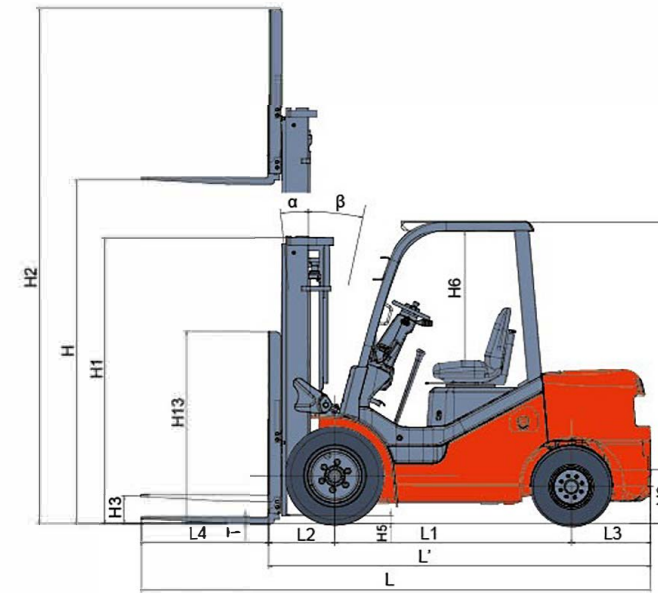

CPC20 CPC25 CPC30 CPC35
CP(Q)(Y)D20 CP(Q)(Y)D25 CP(Q)(Y)D30 CP(Q)(Y)D35
CPCD20 CPCD25 CPCD30 CPCD35

Note: The vertical axis stands for load capacity and the horizontal axis stands for load center which is calculated from the front of the fork. The base point of the standard load refers to the center position of the cube with 1000mm length of side. When mast is tilted forward, nonstandard fork usage or load with over wide goods, load capacity will be reduced. Different load capacity in different load center can be known in time through load chart.

WIDE VIEW MAST

Mast model	Max. lifting height mm	Load capacity (load center 500mm)				Mast overall height (fork to the ground)			Service weight				Mast tilting angle (°) α/β
		CP(Q)(Y)20/ CPC20/CPCD20	CP(Q)(Y)25/ CPC25/CPCD25	CP(Q)(Y)30/ CPC30/CPCD30	CP(Q)(Y)35/ CPC35/CPCD35	2-2.5t	3t	3.5t	CP(Q)(Y)20/ CPC20/CPCD20	CP(Q)(Y)25/ CPC25/CPCD25	CP(Q)(Y)30/ CPC30/CPCD30	CP(Q)(Y)35/ CPC35/CPCD35	
M200	2000	2000	2500	3000	1495	1570	1680	3340	3720	4280	4700	6/12	
M250	2500	2000	2500	3000	1745	1820	1930	3385	3765	4335	4750	6/12	
M300	3000	2000	2500	3000	1995	2080	2180	3420	3800	4370	4800	6/12	
M330	3300	2000	2500	3000	2145	2220	2330	3460	3840	4395	4830	6/12	
M350	3500	2000	2500	3000	2245	2320	2430	3480	3860	4420	4850	6/12	
M370	3700	2000	2500	3000	2345	2420	2530	3500	3880	4430	4870	*6/12	
M400	4000	2000	2500	3000	2545	2620	2730	3565	3945	4490	4940	*6/12	
M425	4250	*1900	*2250	*2850	2670	2745	2855	3590	3970	4510	4970	*6/12	
M450	4500	*1800	*2150	*2750	2795	2870	2980	3615	3995	4535	4990	*6/12	
M500	5000	*1600	*1950	*2400	3045	3120	3230	3655	4035	4575	5040	*6/6	
M550	5500	*1700	*2200	*2850	3345	3420	3530	3740	4120	4745	5245	*3/6	
M600	6000	*1500	*1800	*2200	3595	3670	3780	3785	4165	4795	5285	*3/6	

Note: (1) *stands for the rated capacity when the front tyre is double-tyre. (2) When the front tyre of the 2-3.5t truck is double tyre, the service weight of the truck is the weight in the table plus 110kg.

Performance																	
Model		CPC20	CPCD20	CPC25	CPCD25	CPC30	CPCD30	CPC35	CPCD35	CP(QXY)20	CP(QY)D20	CP(QXY)25	CP(QY)D25	CP(QXY)30	CP(QXY)D30	CP(QY)35	CP(QY)D35
Max.drawbar pull (Loaded/Unloaded)	kN	14.5/12.3	16/12.8	18/12.4	18.7/13.8	17/14.5	19/14.5	18/14.5	21/14.5	15/12.5	16/12.8	15/12.3	16.5/12.4	17/13.5	18/13.5	18/13.5	20/13.5
Max.Gradeability (Loaded/Unloaded)	%	30/25	39/28	27/23	35/23	21/23	29/22	15/22	23/22	30/25	39/28	27/23	35/23	21/23	29/22	15/22	23/22
Max.traveling speed (Loaded/Unloaded)	km/h		17/19		17/19		19/20		19/19		17/19		17/19		19/20		19/20
Lifting Speed (Loaded/Unloaded)	mm/s		560/600		560/600		500/550		400/420		520/570		520/570		420/480		370/410
Lowng Speed (Loaded/Unloaded)	mm/s		450/500		450/500		450/550		350/400		450/500		450/500		450/550		350/400
Drive and transmission control device																	
Engine mode				ISUZU C240					ISUZU 4JG2					GCT K25			
Engine rated power	kW/rpm			35.4/2500					44.9/2450					37.4/2400			
Engine rated torque	Nm/rpm			139.9/1800					184.7/1600~1800					176.5/1600			
Engine cylinder number-borexstroke				4-86×102					4-95.4×107					4-89×100			
Engine displacement	L			2.369					3.05					2.488			
Engine type				Diesel					Gasoline or LPG					Gasoline or LPG			
Emission				Euro Stage IIIA													
Battery(Voltage/Capacity)	V/Ah			12/80					60					12/60			
Engine fuel tank capacity	L								60								
Transmission box shifting gears (Front/Rear type)									1-1Power Shift T/M / 2-2 Manual Shift T/M								

Note:*stands for theoretical calculating value.

Engine Model and Main Specification for Option

Engine model	Rated power/ rotating speed (Kw/rpm)	Rated power/ rotating speed (Nm/rpm)	Engine displacement (L)	Engine cylinder number	Cylinder number - BorexStroke	Engine type	Emission
ISUZU 4JG2	35/2450	170/1700	3.05	4	4-95.4x107	Diesel	Euro Stage IIIA
KUBOTAV2403	34.1/2400	155.9/1600	2.434	4	4-87×102.4	Diesel	Euro Tier III A/EPA T4I
Cummins QSF2.8	36/2500	186/1100~1500	2.8	4	4-94x100	Diesel	Euro Tier IIIA
Cummins QSF2.8	43/2500	186/1100~1500	2.8	4	4-94X100	Diesel	Euro Tier IIIA
DACHAI CA498	45/2500	196/1800	3.168	4	4-98x105	Diesel	-
JMC HJ493	39/2500	165/1800	2.771	4	4-93x102	Diesel	-
JMC HJ493G43	36.5/2500	156/1800	2.771	4	4-93x102	Diesel	Euro Tier IIIA
GCT K21	31.2/2200	143.7/1600	2.065	4	4-89x83	Gasoline or LPG	-
Mitsubishi 4G64	GAS:48/2700 LPG:46/2700	GAS:170/2400 LPG:168/1600	2.351	4	4-86.5×100	Gasoline or LPG	-

WIDE VIEW FULL FREE 2-STAGE MAST

Mast model	Max. lifting height mm	Load capacity (load center 500mm)				Mast overall height (fork to the ground)			Free lifting height (with backrest)			Service weight				Mast tilting angle (°) α/β
		CP(QXY)20/ CPC20/ CPCD20	CP(QXY)25/ CPC25/ CPCD25	CP(QXY)30/ CPC30/ CPCD30	CP(QXY)35/ CPC35/ CPCD35	2-2.5t	3t	3.5t	2-2.5t	3t	3.5t	CP(QXY)20/ CPC20/ CPCD20	CP(QXY)25/ CPC25/ CPCD25	CP(QXY)30/ CPC30/ CPCD30	CP(QXY)35/ CPC35/ CPCD35	
ZM200	2000	2000	2500	3000	3500	1495	1570	1680	495	340	460	3470	3850	4330	4770	6/12
ZM250	2500	2000	2500	3000	3500	1745	1820	1930	745	590	710	3515	3895	4370	4820	6/12
ZM300	3000	2000	2500	3000	3500	1995	2080	2180	995	840	960	3550	3945	4420	4870	6/12
ZM330	3300	2000	2500	3000	3500	2145	2220	2330	1145	990	1110	3595	3975	4445	4895	6/12
ZM350	3500	2000	2500	3000	3500	2245	2320	2430	1245	1090	1210	3615	3995	4465	4915	6/12
ZM370	3700	2000	2500	3000	3500	2345	2420	2530	1345	1200	1310	3635	4015	4480	4935	6/12
ZM400	4000	2000	2500	3000	3500	2545	2620	2730	1545	1390	1510	3705	4085	4550	5000	6/12
ZM425	4250	1900	2250	2850	3100	2670	2745	2855	1670	1515	1635	3730	4110	4575	5025	6/12
ZM450	4500	1800	2150	2750	3000	2795	2870	2980	1795	1640	1760	3755	4135	4595	5050	6/12
ZM500	5000	1600	2400	3000	3500	3045	3120	3230	2045	1890	2010	3805	4185	4640	5100	6/12
ZM550	5500	1500	2200	2850	3250	3345	3420	3530	2345	2190	2310	3890	4270	4830	5295	3/6
ZM600	6000	1500	1800	2200	2300	3595	3670	3780	2595	2440	2560	3935	4315	4875	5350	3/6

Note:(1) *stands for the rated capacity when the front tyre is double-tyre.

(2) When the front tyre of the 2-3.5t truck is double tyre, the service weight of the truck is the weight in the table plus 110kg.

(3) The free lifting height (without backrest) of the 2-2.5t truck is the height (with backrest) in the table plus 432mm. The free lifting height (without backrest) of the 3t truck is the height (with backrest) in the table plus 568mm. The free lifting height (without backrest) of the 3.5t truck is the height (with backrest) in the table plus 505mm.

WIDE VIEW FULL FREE 3-STAGE MAST

Mast model	Max. lifting height mm	Load capacity (load center 500mm)				Mast overall height (fork to the ground)			Free lifting height (with backrest)			Service weight				Mast tilting angle (°) α/β
		CP(QXY)20/ CPC20/ CPCD20	CP(QXY)25/ CPC25/ CPCD25	CP(QXY)30/ CPC30/ CPCD30	CP(QXY)35/ CPC35/ CPCD35	2-2.5t	3t	3.5t	2-2.5t	3t	3.5t	CP(QXY)20/ CPC20/ CPCD20	CP(QXY)25/ CPC25/ CPCD25	CP(QXY)30/ CPC30/ CPCD30	CP(QXY)35/ CPC35/ CPCD35	
ZSM360	3600	2000	2400	2900	3200	1795	1930	1930	795	705	710	3715	4095	4610	4925	6/6
ZSM400	4000	1900	2400	2900	3200	1920	2055	2055	920	830	835	3745	4125	4640	4955	6/6
ZSM435	4350	1850	2200	2800	2900	2045	2180	2180	1045	955	960	3775	4155	4665	4980	6/6
ZSM450	4500	1750	2150	2700	2800	2095	2230	2230	1095	1005	1010	3785	4165	4680	4995	6/6
ZSM470	4700	1720	2300	2800	2900	2160	2230	2230	1160	1005	1010	3800	4180	4700	5015	6/6
ZSM480	4800	1700	2300	2800	2900	2195	2330	2330	1195	1105	1110	3805	4185	4720	5025	6/6
ZSM500	5000	1600	2400	2900	3000	2295	2430	2430	1295	1205	1210	3830	4210	4745	5060	6/6
ZSM540	5400	1450	2250	2750	2850	2420	2555	2555	1420	1330	1335	3860	4240	4775	5090	3/6
ZSM600	6000	1200	2100	2600	2700	2645	2780	2780	1645	1555	1560	3940	4320	4865	5180	3/6

Note:(1) *stands for the rated capacity when the front tyre is double-tyre.

(2) When the front tyre of the 2-3.5t truck is double tyre, the service weight of the truck is the weight in the table plus 110kg.

(3) The free lifting height (without backrest) of the 2-2.5t truck is the height (with backrest) in the table plus 445mm. The free lifting height (without backrest) of the 3-3.5t truck is the height (with backrest) in the table plus 554mm.