

HELI

中国合力 提升未来



始于 1958

1.6-1.8t

G SERIES AC ELECTRIC

NARROW AISLE REACH TRUCK



 **series** / INTELLIGENT
ENVIRONMENT-FRIENDLY

Manufacturer's Data and Design Characteristics

Characteristics								
1.01	Manufacturer				HELI			
1.02	Model			CQD16X1			CQD18X1	
1.03	Configuration number			GB2R			GB2R	
1.04	Load Capacity	Q	lb	kg	3527	1600	4000	1800
1.05	Load center	C	in	mm	24	600	24	600
1.06	Power model				Electric			
1.07	Driving model				Stand			
1.08	Wheel Base	L2	in	mm	55	1407	57	1457
1.09	Votage		v	v	36/48	36/48	36/48	36/48
Tyre								
2.01	Tyre type				PU	PU	PU	PU
2.02	wheel nubur,drive/load/caster(X=drive wheel)				1×4/2	1×4/2	1×4/2	1×4/2
2.03	Wheel size,load		in	mm	Φ5×3.7	Φ127×95	Φ5×3.7	Φ127×95
2.04	Wheel size,drive		in	mm	Φ13×5.5	Φ330×140	Φ13×5.5	Φ330×140
2.05	Wheel size,caster		in	mm	Φ7.4×3	Φ178×76	Φ7.4×3	Φ178×76
Dimensions								
3.01	Lift height	H	in	mm	218	5530	218	5530
3.02	Mast height,lowered	H1	in	mm	99	2526	99	2526
3.03	Free lift	H8	in	mm	59	1490	59	1490
3.04	Fork size,htickness/width/length	s/e/l	in	mm	1.4×3.9×36.2	35×100×920	1.4×3.9×36.2	35×100×920
3.05	Fork adjusting width	W4	in	mm	9.6~28.5	244~724	9.6~28.5	244~724
3.06	Tilt(forward/backward)		deg	deg	3°/4°	3°/4°	3°/4°	3°/4°
3.07	Fork sideshifting		in	mm	±2	±50	±2	±50
3.08	Truck body length(fork excluded)	L	in	mm	71	1815	73	1865
3.09	Truck body width	W	in	mm	43	1090	43	1090
3.10	Straddle leg, inside width	W2	in	mm	33~51	845~1300	33~51	845~1300
3.11	Straddle leg, outside width	W1	in	mm	47~59	1192~1492	47~59	1192~1492
3.12	Fork carriage width	W3	in	mm	33	842	33	842
3.13	Reach distance	S	in	mm	24	600	24	600
3.14	Height of overhead guard	H7	in	mm	91	2320	91	2320
3.15	Battery bottom clearance	H4	in	mm	7	180	7	180
3.16	Straddle clearance	H5	in	mm	2	50	2	50
3.17	Straddle height	H9	in	mm	5	130	5	130
3.18	Step height	H6	in	mm	10	250	10	250
3.19	Minimum turning radius	Wa	in	mm	67	1695	69	1745
3.20	Drive wheel center to truck body rear distance	L1	in	mm	10	252	10	252
3.21	Fork front to truck body rear distance	L4	in	mm	55	1396	55	1396
3.22	Aisle width with pallet 1200Lx1200w	Ast	in	mm	109	2771	111	2812
3.23	Aisle width with pallet 1000Lx1000w	Ast	in	mm	100	2550	102	2591
Performance								
4.01	Travel speed loaded/unloaded		mph	km/h	6.5/7.3	10.5/11.8	6.5/7.3	10.5/11.8
4.02	Lift speed loaded/unloaded		fpm	mm/s	65/100	330/510	65/100	330/510
4.03	Lowering speed loaded/unloaded		fpm	mm/s	98/98	500/500	98/98	500/500
4.04	Reach speed loaded/unloaded		fpm	mm/s	22/30	110/150	22/30	110/150
4.05	Max.gadeability loaded/unloaded - 5 minute rating		%	%	10/15	10/15	10/15	10/15
Weight								
5.01	Total weight(with battery)		lb	kg	7165	3250	7716	3500
5.02	Axle loading, no load (fomt/rear)		lb	kg	4321/2844	1960/1290	4762/2954	2160/1340
5.03	Axle loading, loaded (fomt/rear)		lb	kg	3527/7165	1600/3250	3968/7606	1800/3450
Battery								
6.01	Battery voltage/capacity k5		kwh	Ah	28	775	28	775
6.02	Battery voltage/capacity k5		kwh	Ah	18	500	18	500
6.03	Minimum battery weight		lb	kg	1764	800	2072	940
6.04	Battery box dimension		in	mm	39×14×31	985×365×788	39×16×31	985×415×788
Motor and controller								
7.01	Driving motor power		HP	kw	9.4	7	9.4	7
7.02	Lifting motor power		HP	kw	20.1	15	20.1	15
7.03	Steering motor power		HP	kw	0.8	0.6	0.8	0.6
7.04	Type of driving control				MOSFET/AC			
7.05	Type of lifting control				MOSFET/AC			
7.06	Type of steering control				MOSFET/AC			
7.07	Transmission box				HELI special			
7.08	Service brake				Electric			
7.09	Hydraulic system working pressure		PSI	Mpa	3050			

NOTE: For detailed information about battery,please contact your authorized HELI dealer.

These are "Zero Clearance" aisles in the table and require an additional 150mm or more to be added to provide for easier maneuvering.



WIDE VIEW FULL FREE 3-STAGE MAST

Mast model	Fork Height h3 (in)(mm)				Free lifting height h3 (in)(mm)				Mast height h1 (in)(mm)				Load Capacity at 24" Load Center (lb) (kg)				Service Weight (lb) (kg)			
	CQD16X1		CQD18X1		CQD16X1		CQD18X1		CQD16X1		CQD18X1		CQD16X1		CQD18X1		CQD16X1		CQD18X1	
ZSM502	198	5025	198	5025	55	1390	55	1390	95	2413	95	2413	3527	1600	3968	1800	7374	3345	7672	3480
ZSM533	210	5330	210	5330	59	1490	59	1490	99	2526	99	2526	3527	1600	3858	1750	7419	3365	7716	3500
ZSM610	240	6095	240	6095	69	1745	69	1745	109	2781	109	2781	3527	1600	3858	1750	7573	3435	7871	3570
ZSM685	270	6855	270	6855	79	2000	79	2000	120	3036	120	3036	2425	1100	2866	1300	7683	3485	7981	3620
ZSM762	300	7620	300	7620	90	2285	90	2285	131	3321	131	3321	2094	950	2425	1100	7837	3555	8135	3690

AST: Right angle stacking aisle width
a: Clearance a=150mm

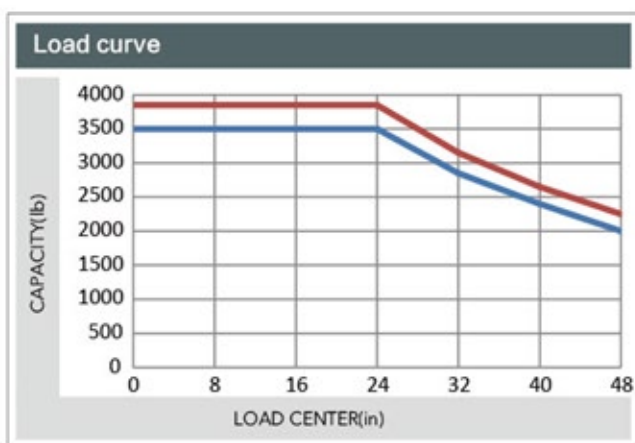
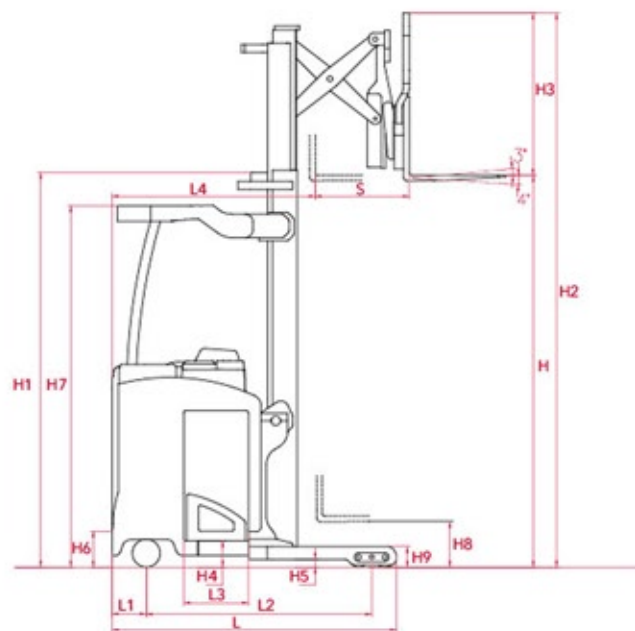
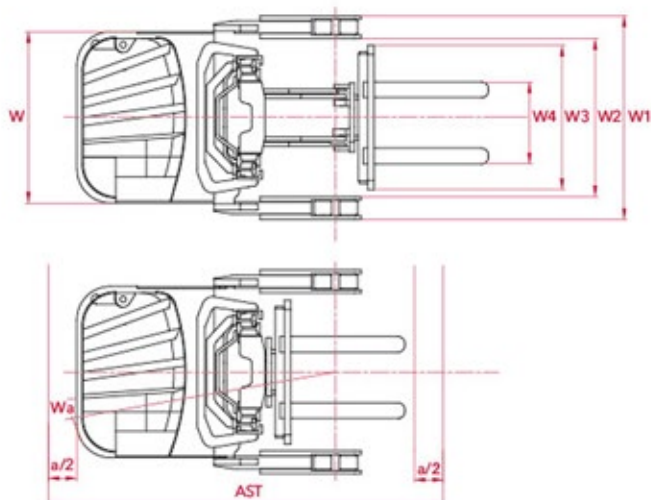

— CQD16X1
— CQD18X1

NOTE: The vertical axis is the load capacity, and the horizontal axis is the load center which is calculated from the front face of the forks to the load center of gravity. Capacity curves shown are for a standard mast at zero degree tilt with standard forks. Changing mast tilt, using non-standard forks or loading large goods can affect load capacity. This chart can be used to estimate load capacity at various load centers for standard masts. Contact HELI for specific load ratings for your situation.



THE PERFORMANCE OF BATTERY INCREASES

Renewable energy technologies

↑ 15%

With the use of AC controlling renewable energy technologies, the forklift is more energy-saving and the working hour of the battery is extended by 15%.

Certifications: These HELI models are CE&CQC certified and also meet all requirements of ANSI B56.1-2012 and OSHA Regulation 29CFR1910.178. All dimensional and performance specifications shown are for reference and subject to change without notice.

The reliable special instrument gives a complete display of the vital information, like operation status, fault detection, etc. It ensures the operator predominate the vehicle status more intuitive and convenient.



ZAPI high level meter (for GB2R truck model)

* Details of specifications and equipment are based on information available at time of printing and may change without notice.

HELI

NEW ZEALAND

45 Percy Cameron Street Avalon Lower Hutt
 Phone : 0800 538 735
 Email : sales@heliforklifts.co.nz
 Web : www.heliforklifts.co.nz

AUTHORIZED DEALER

Catalog No.180604 Fokeli Print