

## Reliable special designed instrument



Back Up Down OK

1. Colorful LCD display screen with high resolution; adjustable backlight brightness;
2. CAN bus meter to read the fault code directly; ( only electronic controlled engine )
3. Front and rear protection degree: IP 66
4. Working temperature: -30°C~+75°C; temperature for storage: -40°C~+85°C;
5. Multi-level programmable menu;
6. More than 20 alarm indicators and 6 simulation indicators can monitor engine and trucks at the same time to protect operator and truck safety;
7. Alarm according to different grade: there are two alarm grade: the indicator will flicker for the first grade alarm and the buzzer will sound up for the second grade alarm;
8. Chinese and English are optional.
9. Point check;
10. Identity recognition (optional); Starting through card or password (optional).
11. GPS (optional)

	Engine coolant temperature
	Fuel level
	Oil temperature of drive axle
	LPG pressure
	Low brake pressure
	Engine alarm

	Charging indication
	Block of air cleaner
	Hand brake
	Seat switch
	Neutral indicator
	Safety belt switch

	Left turning
	Right turning
	Alarm of low fuel
	Alarm of engine oil pressure
	Preheating indication
	Hourmeter

	Oil and water separator
	High temperature exhausting
	DPF parking regeneration request
	Forcible no generation of DPF
	Fault of fingertip control

### Standard

Reversing handle (with horn)  
Protection for tilting cylinder  
Protection for steering cylinder  
main switch  
High exhaust  
Warning light  
Flickering warning light  
OPS controller

### Optional

Cab  
Air conditioner  
Heater  
Front windshield  
Rear windshield  
Fire extinguisher  
Fan  
Dual air cleaner  
Fork extension  
Solid tyre  
Widen fork carrier  
Purification extinguisher

Fire muffler  
Fire extinguisher  
Rear working light  
Optional attachment  
Lifting slings  
Protection net of overhead guard  
Rough filter with ash self discharge  
Reversing voice speaker  
Universal key  
Synchronized steering  
Rear view camera  
Warning light

Fingertip operation system  
Overspeed warning  
Speed limit function  
Starting through password or card  
Internet of vehicle  
Smart safety system  
HELI smart fleet management system

Product range of Heli: 1-46 tons internal combustion forklift truck; 0.6-18 tons electric forklift truck; reach truck, pallet truck, stacker and other warehousing products; AGV and system solutions; reach stacker, container handler, tractor, explosion-proof forklift truck, rough terrain forklift truck, bader and other diversified products.



## 3-3.5 t

## G3 series Internal Combustion Counterbalanced Forklift Truck



NEW GENERATION SUPERIOR QUALITY



# 3-3.5 t G3 series Internal Combustion Counterbalanced Forklift Truck

The image of the whole vehicle is fully upgraded, adopting Heli's brand-new family-based PI features, with both appearance and connotation. The Chinese "bronze tripod" shape shows the deep foundation of the enterprise. Heli contributes to the society with high-quality products which have innovational color matching, fashionable and unique characteristics. There is a high degree of brand recognition.

## Improved comfort

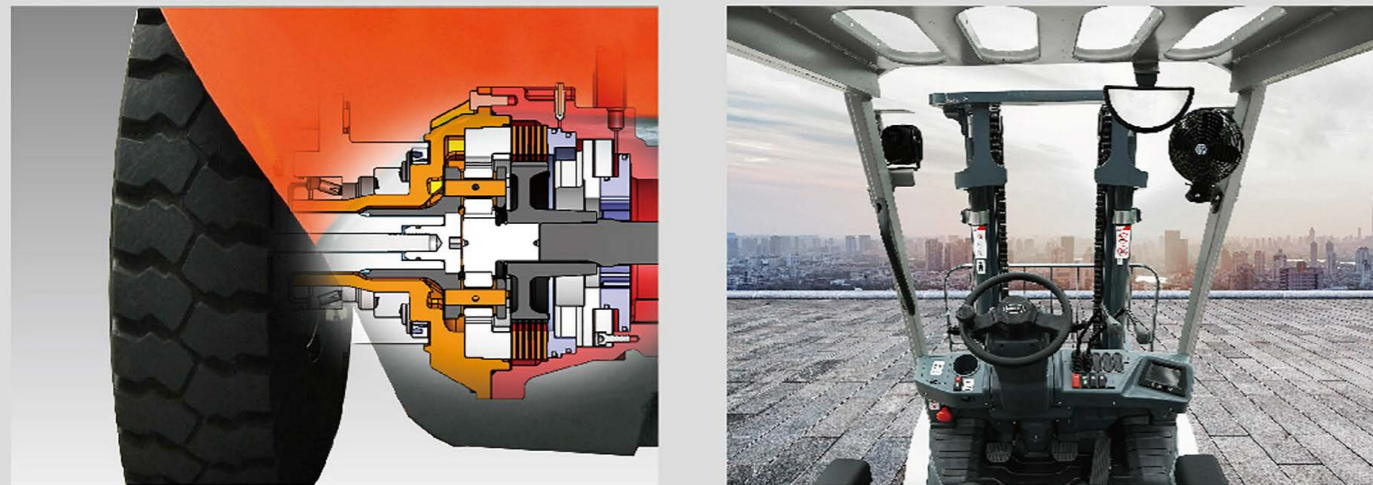

## Upgraded efficiency

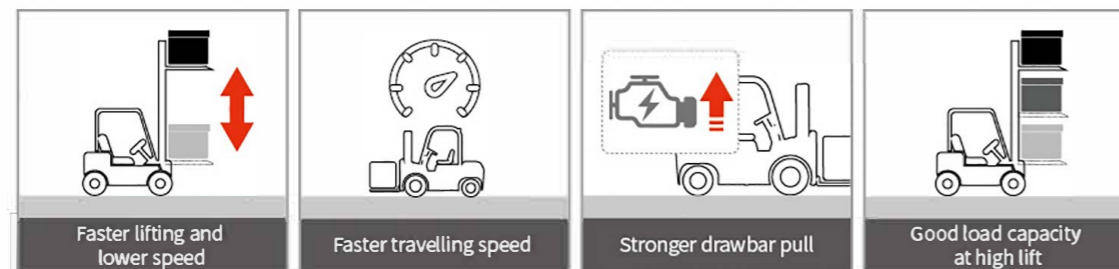

## Safety guaranteed

- The OPS control system meets the latest European standard. When the driver leaves the seat, travelling and the lifting and lowering functions of the mast are locked, effectively ensuring the driver's safety;
- The efficient and reliable parking brake system makes parking safer and more reliable;
- Customized speed control system meet the personalized needs; (optional)
- The truck is equipped with the function of preventing starting with gear and preventing the secondary ignition of engine, and the safety guarantee is upgraded;
- The intelligent instrument can comprehensively monitor the status of the whole truck. realize starting with card or password and maintenance information reminding, and more efficient or flexible truck management can be realized through matching with HELI professional fleet management system;
- The truck is equipped with integral cab which upgrades safety protection.





**Manufacturer and technical data**

Distinguishing marks					
1.1	Manufacturer (abbreviation)			<b>HELI</b>	
1.2	Manufacturer's type designation		CPCD30		CPCD35
1.3	Drive		Diesel/LPG(gas)		
1.4	Operator type		Seated		
1.5	Rated capacity/rated load	Q	kg	3000	3500
1.6	Load centre distance	c	mm	500	500
1.7	Load distance, centre of drive axle to fork	x	mm	494	499
1.8	Wheelbase	y	mm	1800	1800
Weight					
2.1	Service weight		kg	4480	4880
2.2	Axle loading, laden front/rear		kg	6535/945	7365/1015
2.3	Axle loading, unladen front/rear		kg	1875/2605	1925/2955
Tyres/chassis					
3.1	Tyres: solid rubber, superelastic, pneumatic, polyurethane			Pneumatic tyre	Pneumatic tyre
3.2	Tyre size, front			28*9-15-14PR	28*9-15-14PR
3.3	Tyre size, rear			6.50-10-10PR	6.50-10-10PR
3.4	Wheels, number front/rear (x = driven wheels)			2x/2	2x/2
3.5	Tread, front	b <sub>10</sub>	mm	1000	1000
3.6	Tread, rear	b <sub>11</sub>	mm	970	970
Dimensions					
4.1	Tilt of mast/fork carriage forward/backward	α/β	°	6/10	6/10
4.2	Height, mast lowered	h <sub>1</sub>	mm	2120	2120
4.3	Free lift	h <sub>2</sub>	mm	155	160
4.4	Lift	h <sub>3</sub>	mm	3000	3000
4.5	Height, mast extended	h <sub>4</sub>	mm	4220	4220
4.6	Height of overhead guard (cabin)	h <sub>6</sub>	mm	2180	2180
4.7	Seat height/stand height	h <sub>7</sub>	mm	1125	1125
4.8	Coupling height	h <sub>10</sub>	mm	325	325
4.9	Overall length	l <sub>1</sub>	mm	3880	3940
4.10	Length to face of forks	l <sub>2</sub>	mm	2810	2870
4.11	Overall width	b <sub>1</sub>	mm	1225	1225
4.12	Fork dimensions ISO 2331	s/e/l	mm	45/125/1070	50/125/1070
4.13	Fork carriage ISO 2328, class/type A, B			IIIA	IIIA
4.14	Fork-carriage width	b <sub>3</sub>	mm	1100	1100
4.15	Ground clearance, laden, below mast	m <sub>1</sub>	mm	135	135
4.16	Ground clearance, centre of wheelbase	m <sub>2</sub>	mm	145	145
4.17	Aisle width for pallets 1000 × 1200 crossways	Ast	mm	4180	4220
4.18	Aisle width for pallets 800 × 1200 crossways	Ast	mm	4310	4350
4.19	Turning radius	Wa	mm	2425	2460
4.20	Internal turning radius	b <sub>13</sub>	mm	650	650
Type of drive unit					
8.1	Type of drive unit			Hydraulic	Hydraulic
Addition data					
9.1	Operating pressure for attachments		bar	210	210
9.2	Oil volume for attachments		ℓ/min	64	64
9.3	Sound pressure level at the driver's seat				

**WIDE VIEW MAST**

Mast model	Max. lifting height (mm)	Load capacity (load center 500mm)(kg)		Mast height(mm)		Mast tilt angle Front/Rear (°)	Service weight (kg)	
		3t	3.5t	3t	3.5t		3t	3.5t
M300	3000	3000/3000*	3500/3500/3500**	2070	2120	6-10	4480	4880
M330	3300	3000/3000*	3500/3500*/3500**	2220	2270	6-10	4540	4940
M350	3500	3000/3000*	3500/3500*/3500**	2320	2370	6-10	4560	4950
M370	3700	3000/3000*	3500/3500*/3500**	2420	2470	6-10	4580	4970
M400	4000	3000/3000*	3500/3500*/3500**	2620	2670	6-10	4650	5040
M450	4500	3000/3000*	3500/3500*/3500**	2870	2920	6-10	4690	5090
M500	5000	2600/3000*/2750**	3300/3400*/3400**	3120	3170	6-6	4740	5130
M550	5500	2300/2550*/2400**	2650/2950*/2800**	3420	3470	6-6	4830	5220
M600	6000	1900*	2050*	3670	3720	6-6	4870	5260

Note: ①\* stands for rated capacity for trucks with dual front tyre, \*\* stands for rated capacity for trucks with single solid tyre;  
 ② For 2-3.5t trucks with dual front tyre, the service weight is the data in the table plus 110kg.

**WIDE VIEW FULL FREE 2-STAGE MAST**

Mast model	Max. lifting height (mm)	Load capacity (load center 500mm)(kg)		Mast height(mm)		Free lift (with backrest) (mm)		Mast tilt angle Front/Rear (°)	Service weight (kg)	
		3t	3.5t	3t	3.5t	3t	3.5t		3t	3.5t
ZM300	3000	3000/3000*/3000**	3500/3500*/3500**	2070	2120	888	943	6-10	4530	4850
ZM330	3300	3000/3000*/3000**	3500/3500*/3500**	2220	2270	1038	1093	6-10	4560	4880
ZM350	3500	3000/3000*/3000**	3500/3500*/3500**	2320	2370	1138	1193	6-10	4580	4900
ZM370	3700	3000/3000*/3000**	3500/3500*/3500**	2420	2470	1238	1293	6-10	4600	4920
ZM400	4000	3000/3000*/3000**	3500/3500*/3500**	2620	2670	1438	1493	6-10	4680	5000

Note: ①\* stands for rated capacity for trucks with dual front tyre, \*\* stands for rated capacity for trucks with single solid tyre;  
 ② For 2-3.5t trucks with dual front tyre, the service weight is the data in the table plus 110kg.

**WIDE VIEW FULL FREE 3-STAGE MAST**

Mast model	Max. lifting height (mm)	Load capacity (load center 500mm)(kg)		Mast height(mm)		Free lift (with backrest) (mm)		Mast tilt angle Front/Rear (°)	Service weight (kg)	
		3t	3.5t	3t	3.5t	3t	3.5t		3t	3.5t
ZSM435	4350	3000/3000*/3000**	3500/3500*/3500**	2120	2120	938	943	6-6	4700	5040
ZSM450	4500	3000/3000*/3000**	3500/3500*/3500**	2170	2170	988	993	6-6	4720	5050
ZSM470	4700	3000/3000*/3000**	3400/3400*/3400**	2230	2230	1048	1053	6-6	4740	5070
ZSM500	5000	2600/2950*/2750**	3300/3300*/3300**	2370	2370	1188	1193	6-6	4770	5110
ZSM540	5400	1900/2650*/2050**	2700/2850*/2850**	2470	2470	1288	1293	6-6	4800	5140
ZSM600	6000	1500/2050*/1650**	2000/2400*/2150**	2670	2670	1488	1493	6-6	4910	5240
ZSM650	6500	1000/1550*/1100**	1100/1650*/1200**	2870	2870	1688	1693	3-3	4960	5300
ZSM700	7000	900*	1200*	3045	3045	1863	1868	3-3	5010	5350

Note: ①\* stands for rated capacity for trucks with dual front tyre, \*\* stands for rated capacity for trucks with single solid tyre;  
 ② For 2-3.5t trucks with dual front tyre, the service weight is the data in the table plus 110kg.

## Technical data

Performance data								
1.2	Manufacturer's type designation		CPCD30	CPCD35	CPCD30	CPCD35	CP (Q)YD30	CP (Q)YD35
5.1	Travel speed, laden/unladen	km/h	18/18.5	17.5/18	18/18.5	17.5/18	18.5/19	18/18.5
5.2	Lift speed, laden/unladen	m/s	0.51/0.56	0.435/0.45	0.51/0.56	0.42/0.45	0.51/0.56	0.42/0.45
5.3	Lowering speed, lade/unladen	m/s	0.51/0.55	0.455/0.49	0.51/0.55	0.455/0.49	0.51/0.55	0.455/0.49
5.6	Max. drawbar pull, laden/unladen	N	21000/14700	19500/15100	22300/14100	21000/15000	22300/14100	21000/15000
5.7	Gradeability, laden/unladen (2km/h)	%	21/25	20/23	21/24	20/23	21/24	20/23
5.8	Max. gradeability, laden/unladen	%	26/25	24/23	30/24	26/23	30/24	26/23
5.10	Service brake		Hydraulic		Hydraulic		Hydraulic	
Combustion-engine								
7.1	Engine manufacturer/type		Diesel		Diesel		LPG(gas)	
7.2	Engine power according to DIN ISO 1585		Mitsubishi s4s(China stage III/Euro stage V)		KUBOTA V2403(Euro stage V/EPA T4F)		KUBOTA WG2503(Euro stage V)	
7.3	Rated speed	kW	35.4		43.2		43.5	
7.4	Number of cylinders/displacement	min-1	2250		2400		2600	
7.5	Fuel consumption according to VDI cycle	(-)/(cm3)	4/3.331		4/2.434		4/2.491	

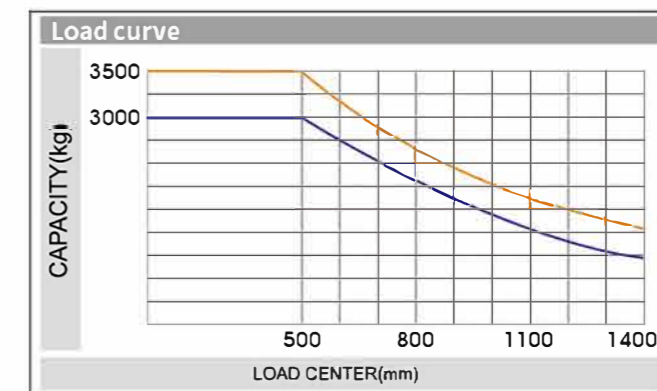
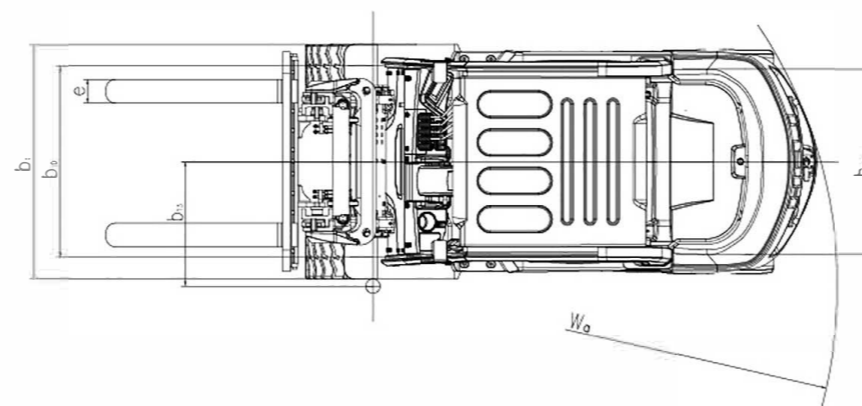
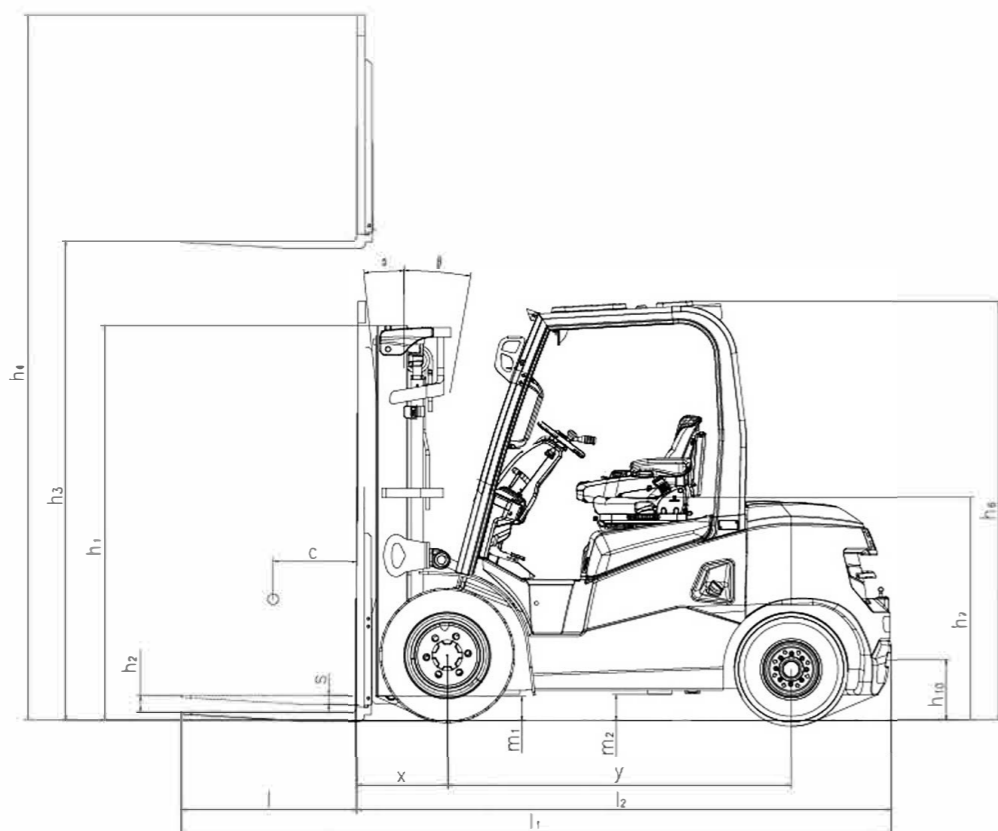

CPCD30 CPCD35

NOTE:

Vertical axis stands for load capacity while horizontal axis stands for load center. Load center is the distance counted from the front of the fork. The base point of the standard load is the center point of the cubic with the same 1200mm dimension in length, width and height. The load capacity should be down, if mask tilts forward, using non-standard forks or loading goods with extra width. Please notice the different load capacity between different load centers according to load chart.