



TB20e

ELECTRIC
COMPACT EXCAVATOR



Operating Weight ■ CANOPY 4,255 lb
Dig Depth ■ 7 ft 10 in
Max Reach ■ 13 ft 4.9 in
100% Battery Powered with Zero Emissions

TAKEUCHI
From World First to World Leader

TOUGH. POWERFUL. RELIABLE.

The TB20e is the latest innovation in the Takeuchi excavator lineup. This fully electric machine is built with the same all steel construction, heavy duty boom and durable undercarriage as all of our excavators. The TB20e comes standard with outstanding operator comfort, easy daily maintenance points, retractable undercarriage, and an on-board charger for simple recharging after the workday. On a full charge the TB20e will run for approximately 8 hours at 65% load. Going fully electric with the TB20e will provide an abundant amount of productivity for operators by reducing downtime by delaying routine maintenance and reduce overall operating costs that comes with traditional construction equipment.

**On-Board Charger for
Operation while Charging**

**Takeuchi Fleet
Management**

**Environmentally
Friendly**
100% Battery Powered
with Zero Emissions

**Wraparound
Counterweight**



PRODUCT FEATURES & SPECIFICATIONS

ZERO EMISSION ELECTRIC POWER

- 24.7 kWh Lithium-Ion Battery
- 100% Battery Powered with Zero Emissions
- Reduced Sound and Vibration Levels
- ECO Mode

ELECTRICAL

- Weather Resistant Rocker Switches
- LED Light Package; Boom, Canopy, Rear
- Travel Alarm
- 12v Battery Disconnect Switch
- TFM (Takeuchi Fleet Management)
- Hour Meter/Trip Meter
- 12v Power Outlet

CHARGING

- Onboard Charger, 95v to 265v Single Phase
- Portable Offboard Charger, 408v to 552v (3) Phase (Optional)

OPERATOR STATION

- 4.3 in. High Definition, Multifunction Color Display
- ISO/SAE Pattern Change Valve via Monitor
- ROPS/TOPS/OPG (Level 1)
- Suspension Seat
- 2 in. Retractable Seat Belt
- 3 in. Non-Retractable Seat Belt (Optional)
- Foldable Travel Pedals
- Boom Swing Pedal, with Foldable Guard
- Emergency Stop Switch
- Safe Start System (Left Console)

UNDERCARRIAGE AND FRAME

- Triple Flange Track Rollers
- Hydraulically Retractable Undercarriage
- Adjustable Width Backfill Blade
- Integrated Load Sensing Automatic Shift Down
- Wraparound Protective Counterweight
- 9 in. (230 mm) Rubber Tracks

TAKEUCHI FLEET MANAGEMENT

- 2 Year Standard Service
- Minimize Downtime
- Remote Diagnostics
- Utilization Tracking
- Proactive Maintenance
- Control Costs
- Geofencing

WORKING EQUIPMENT

- Boom Swing
- Cushioned Boom and Swing Cylinders
- Top Mount Boom Cylinder
- 3 ft. 8.5 in. (1,130 mm) Arm
- Boom Holding Valve

ELECTROHYDRAULIC

- 2 Electric Motors
- Load Sensing System for Operation
- Two Motor Linked Fixed Displacement Gear Pumps
- P1 – Bucket, Boom, Travel, Arm, 1st Auxiliary, Boom Swing, Blade Pilot Pressure
- P2 Slew
- Electrohydraulic Joysticks
- Primary Auxiliary Circuit with Proportional Control
- Detent for Primary Auxiliary Circuit
- Primary Auxiliary Plumbed to mid Arm
- Steel Hydraulic Tank with Fluid Level Sight Gauge
- Pilot Accumulator
- Air Breather
- Adjustable Hydraulic Flow on Primary Auxiliary



*Functions may not be available in all countries, so please consult your Takeuchi dealer for details.

OPERATING PERFORMANCE

Operating Weight - Canopy	4255 lb	1,930 kg
Slew Speed	7.6 rpm	
Travel Speed		
1st	1.3 mph	2.1 km/h
2nd	2.5 mph	4.0 km/h
Gradeability	15°	
Ground Pressure - Canopy	4.7 psi	32.1 kPa
Maximum Bucket Breakout Force	4,226 lbf	1,917 kgf
Maximum Arm Digging Force	1,820 lbf	826 kgf
Traction Force	4,655 lbf	2,116 kgf
Boom Swing Angle (Left/Right)	78° / 49°	

LITHIUM ION BATTERY

Battery Capacity	24.7 kWh
Battery Voltage	73V
Continuous Working Time	Up to 8 Hours*
Battery Charge Hours	20-80%
Off-board Charger @ 400V	2 hours
On-board Charger @200V	6 hours
Input Voltage When Charging	
Off-board Charger	408-552V
On-board Charger	95-265V

HYDRAULIC SYSTEM

P1		
Flow Rate	13.4 gpm	50.7 L/min
Relief Pressure	2990 psi	20.6 MPa
P2		
Flow Rate	2.6 gpm	9.7 L/min
Relief Pressure	2,840 psi	19.6 MPa
Service Port		
Flow Rate	9 gpm	34.0 L/min
Hydraulic Pressure	2,610 psi	18.0 MPa
Hydraulic Reservoir Capacity	3.7 gal	14.1 L
Hydraulic System Capacity	6.3 gal	24.0 L

SAFETY and HEALTH

Noise Level	
Sound Power Level	LWA 80 dB

LEAD-ACID BATTERY

Battery Capacity (IEC 60095-1)	12V-45A * h
--------------------------------	-------------



ATTACHMENTS

Takeuchi offers attachments for all your Takeuchi equipment. See your authorized Takeuchi dealer for additional information and attachment options.

Easy Service
Access

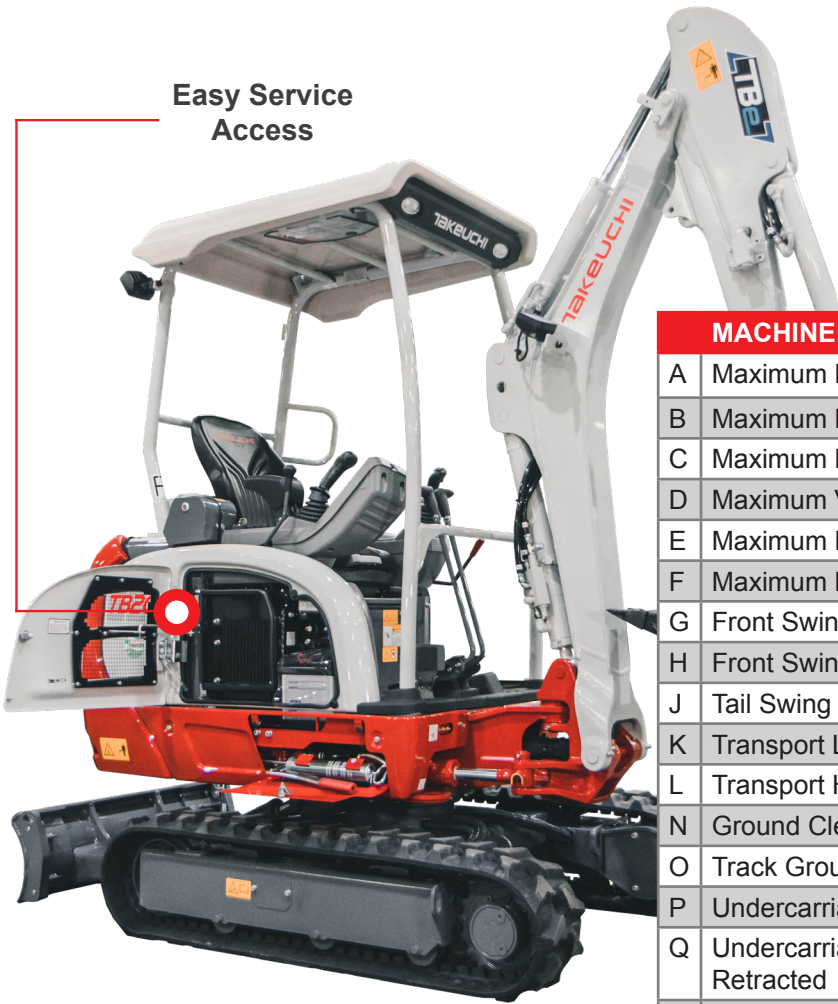

MACHINE DIMENSIONS

MACHINE DIMENSIONS			
A	Maximum Reach	13 ft 4.9 in	4090 mm
B	Maximum Reach at Ground Level	13 ft 2.9 in	4035 mm
C	Maximum Digging Depth	7 ft 10.0 in	2390 mm
D	Maximum Vertical Digging Depth	6 ft 9.0 in	2060 mm
E	Maximum Height of Cutting Edge	12 ft 3.4 in	3740 mm
F	Maximum Dumping Height	8 ft 10.6 in	2705 mm
G	Front Swing Radius	4 ft 10.2 in	1480 mm
H	Front Swing Radius with Boom Offset	3 ft 9.4 in	1155 mm
J	Tail Swing Radius	3 ft 6.4 in	1075 mm
K	Transport Length	13 ft 3.1 in	4040 mm
L	Transport Height (Canopy)	7 ft 5.8 in	2280 mm
N	Ground Clearance	8.1 in	205 mm
O	Track Ground Contact Length	3 ft 9.5 in	1,155 mm
P	Undercarriage Length	4 ft 11.8 in	1,520 mm
Q	Undercarriage Width - Track Retracted	38.6 in	980 mm
	Undercarriage Width - Track Extended	51.2 in	1,300 mm
R	Track Width	9.1 in	230 mm

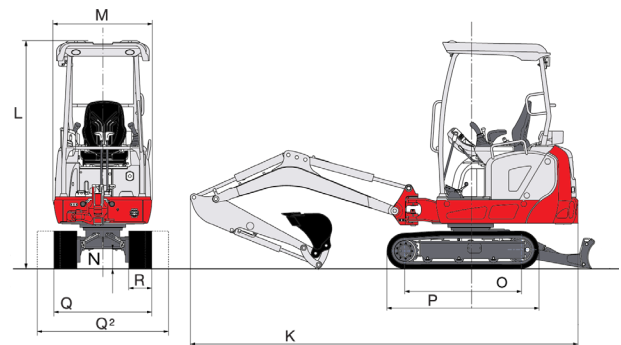
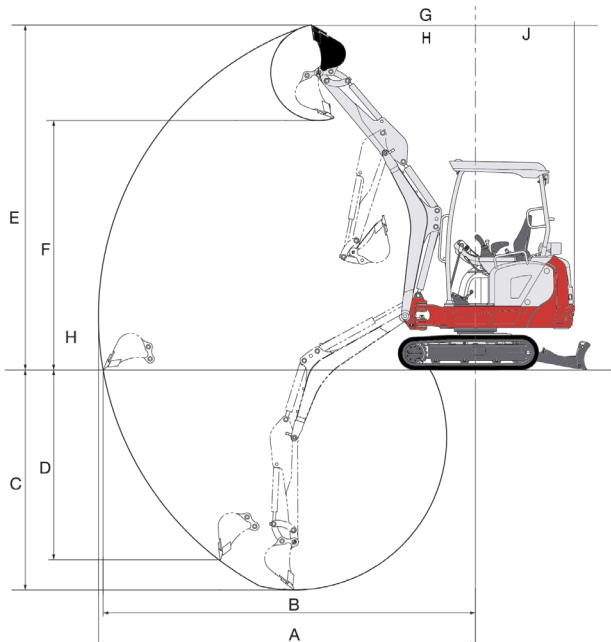

TB20e



© 2023 Takeuchi MFG. Co., Ltd. All Rights Reserved. In accordance with our established policy of continued improvement, specifications and features are subject to change without notice. Pictures may show options other than standard equipment.

FORM: TB20e Compact Excavator Spec Sheet - Feb. 2023

TAKEUCHITM
From World First to World Leader